

# Brushless Motor Spindle

# SFIDA

## 01 Series



스트레이트 스피들

Straight Spindle

배면접속

**MS01-R03** 배면접속 코드 30cm  
Rear Connection 30cm Cord

**MS01-R20** 배면접속 코드 2m  
Rear Connection 2m Cord

측면접속

**MS01-L03** 측면접속 코드 30cm  
Rear Connection 30cm Cord

**MS01-L20** 측면접속 코드 2m  
Rear Connection 2m Cord

이상적인 세라믹 베어링 배치에 의한 고내구성을 실현



MAX Speed **60,000min<sup>-1</sup>**  
MAX Torque **8.82 c N·m**  
MAX Power **370W**

스핀들 정밀도: 1μ 이내  
Spindle Accuracy (※): Less than 1 μm.

(※)---스핀들 테이퍼부분의 내면정밀도를 표현한 것 (콜렛 장착시의 원통정밀도를 표현하는 것이 아님)  
(※)---This "Spindle Accuracy" does not represent the runout accuracy of spindle with collets attached, but rather the accuracy of tapered area of inner spindle.

치수 Dimension

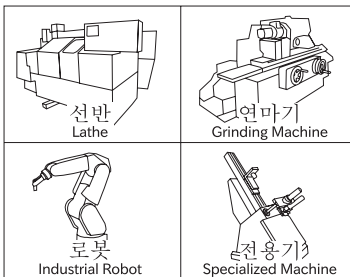
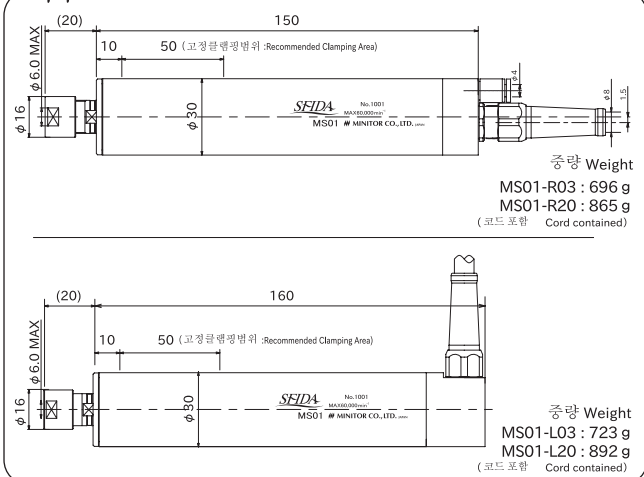

컨트롤 팩  
Control Pack

◆MT01CP-\*\*\*



콜렛 척 [MCC-\*\*\*] 스피들 접속 코드는 별도 판매입니다. [MKD-\*\*\*]  
Collets and Spindle Connection Cords are sold separately.

스트레이트 스피들 표준 부속품 Standard Accessories for Straight Spindle

<p>척 너트 Chuck Nut</p> <p>◆MCN1</p>	<p>스패너 Spanner</p> <p>◆MSP1 1Set : 2 Pieces</p>	<p>에어 호스 Air Hose</p> <p>◆AH4-40 φ4.0×4m</p>
------------------------------------	---	--

MS01시리즈의 옵션 액세서리는 카타로그의 마지막 부분을 참조해 주세요.  
Please refer to the end of the catalogue for Optional Accessories of Straight Spindle.

MS01 / MZ01 성능특성 MS01 / MZ01 Performance Property

출력특성 Output Power Characteristics

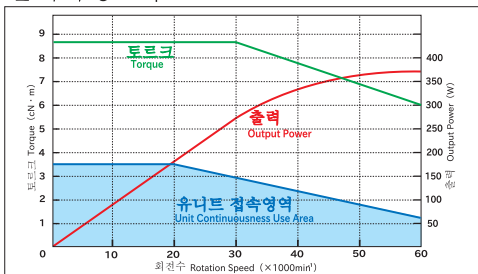

동적주축변위량 Spindle Displacement

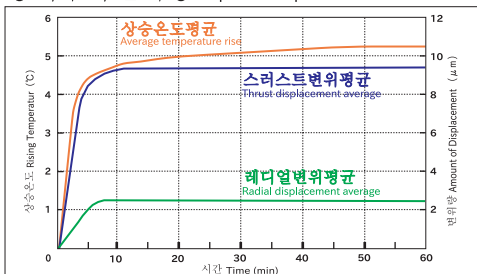

설정 속도 도달 시간 Setting Speed Attained Time

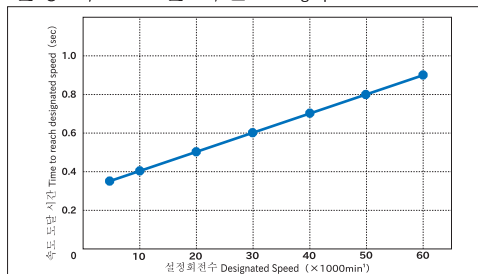

MS01 시스템 차트 MS01 System Chart

1선 접속 Single Connection

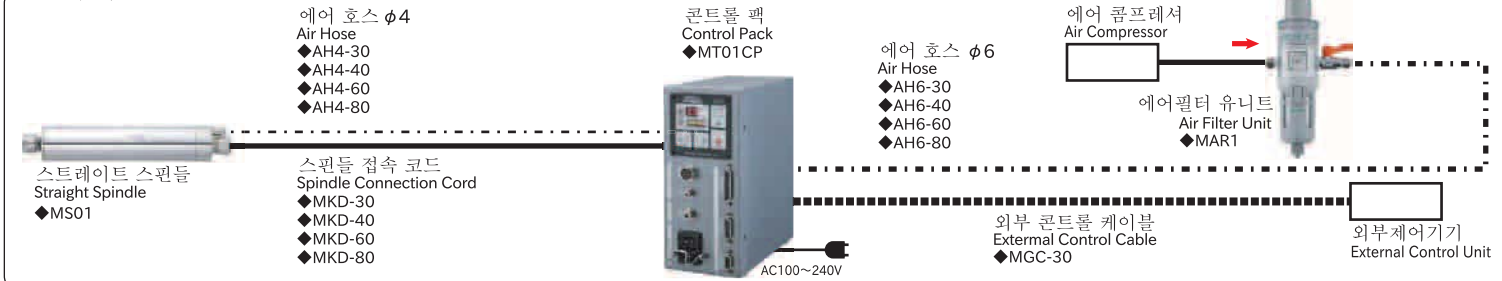

복수 접속 Multiple Connection

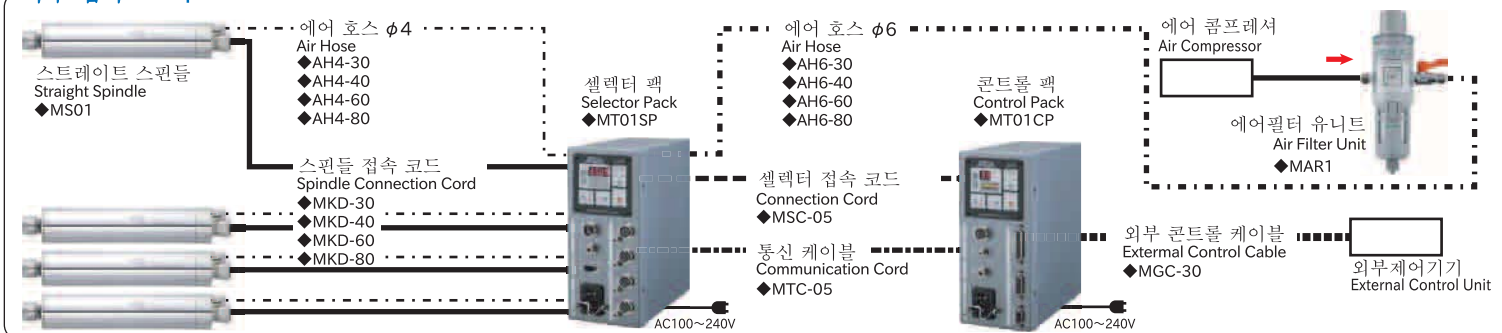

테이퍼샤크 스피들

하이스펙으로 고속가공을 실현합니다.



Tapered Shank Spindle

MZ01 Series

BT Shank HSK Shank  
SK Shank CAT Shank  
ST Shank NT Shank

MAX Speed **60,000min<sup>-1</sup>**  
MAX Torque **8.82 c N·m**  
MAX Power **370W**

스피들 정밀도: 1μ 이내  
Spindle Accuracy (\*1) : Less than 1 μ m.

(\*1)---스피들 테이퍼부분의 내면정밀도를 표현한 것 (콜렛 장착시의 진동정밀도를 표현하는 것이 아님.)  
(\*1)---This "Spindle Accuracy" does not represent the runout accuracy of spindle with collets attached, but rather the accuracy of tapered area of inner spindle.



콘트롤 팩  
Control Pack

◆MT01CP-\*\*\*



콜렛 및  
[MCC-\*\*\*]



스피들 접속 코드는 별도 판매입니다.  
[MKD-\*\*\*]

Collets and Spindle Connection Cords are sold separately.

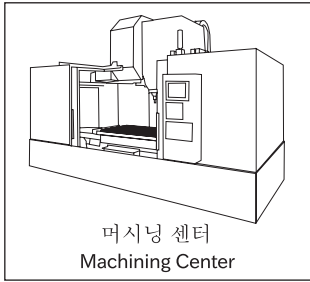

머시닝 센터  
Machining Center

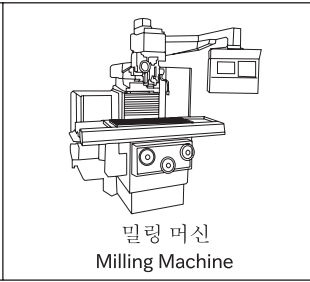

밀링 머신  
Milling Machine

테이퍼샤크 스피들 표준 부속품

Standard Accessories to Taperd Shank Spindle

척 너트

Chuck Nut

스페너

Spanner

에어 호스

Air Hose



◆MCN1



◆MSP1

1Set : 2 Pieces



◆AH4-40

φ 4.0×4m

테이퍼샤크 스피들의 옵션 액세스리는 카탈로그의 마지막 부분을 참조해 주세요.  
Please refer to the end of the catalogue for Optional Accessories of Taperd Shank Spindle.

BT Shank

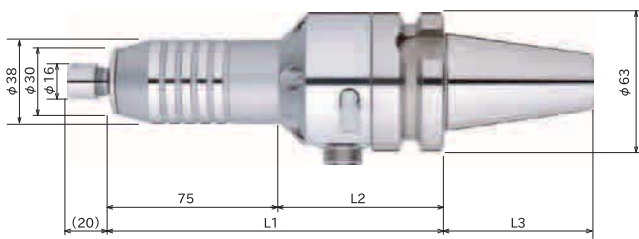

상품 코드 Product Code	사이즈 Dimension (mm)			중량 Weight (kg)
	L1	L2	L3	
MZ01-BT30	165	90	48	2.1
MZ01-BT40	150	75	65.4	2.2
MZ01-BT50	160	85	101.8	4.8

SK Shank

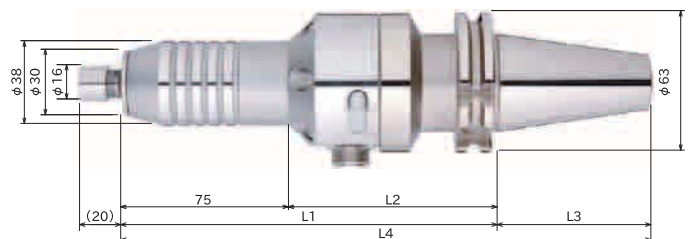

상품 코드 Product Code	사이즈 Dimension (mm)				중량 Weight (kg)
	L1	L2	L3	L4	
MZ01-SK40	170	95	68.4	238.4	2.3
MZ01-SK50	160	85	101.75	261.75	4.9

ST Shank

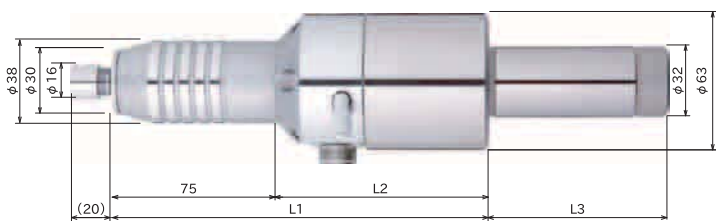

상품 코드 Product Code	사이즈 Dimension (mm)			중량 Weight (kg)
	L1	L2	L3	
MZ01-ST32	172	97	80	2.8

주문 생산 Available upon Request



HSK Shank

MZ01-HSK32A  
MZ01-HSK63A  
MZ01-HSK100A



CAT Shank

MZ01-CAT40  
MZ01-CAT50



NT Shank

MZ01-NT30  
MZ01-NT40  
MZ01-NT50

MZ01 Series 시스템 차트 MZ01 Series System Chart





**고성능, 고출력 콘트롤 팩**  
콘트롤 팩

Control Pack

**MT01CP-100**

부속: AC100V코드

Standard Accessories : 100V AC Power Cord

**MT01CP-120 MT01CP-240**

부속: AC120V코드

부속: AC240V코드

Standard Accessories:  
120V AC Power Cord

Standard Accessories:  
240V AC Power Cord

● 본 제품은 스펀들 내부에 냉각액 등의 투입을 방지하기 위해 메인전원을 OFF로 해도 스펀들에 냉각에어를 계속 공급할 수 있는 구조로 되어 있습니다.  
에어 공급 정지는 공급원의 에어 밸브등으로 정지해 주세요.

● This Control Pack, in an effort of protecting spindle from coolant and chips going inside, keeps blowing cooling air even when the main power supply switch is off.  
When you need to stop the air blow, please do so with the valve attached to the air supplier.

**사양 Specification**

전원	Power Source	AC100~240V
회전속도	Rotation Speed	1,000~60,000min <sup>-1</sup>
최대출력	Maximum Power	370W
치수	Dimension	100 (W)×194 (D)×230 (H)
중량	Weight	4.1kg



**콘트롤 팩(에어밸브 등)**  
Control Pack with Air Valve

**MT01CP-100S**

부속: AC100V코드

Standard Accessories : 100V AC Power Cord

**MT01CP-120S MT01CP-240S**

부속: AC120V코드

부속: AC240V코드

Standard Accessories:  
120V AC Power Cord

Standard Accessories:  
240V AC Power Cord

● 메인전원의 ON/OFF로 연동 하고, 스펀들의 냉각에어 공급을 제어 하는 에어밸브등 콘트롤 팩 입니다.  
메인전원 ON : 에어 공급  
메인전원 OFF : 에어 정지

● Control Pack with air valve that controls the supply of cooling air to spindle in conjunction with ON/OFF mode of main power supply.  
Main power is ON : Air supply is ON  
Main power is OFF : Air supply is OFF

**사양 Specification**

전원	Power Source	AC100~240V
회전속도	Rotation Speed	1,000~60,000min <sup>-1</sup>
최대출력	Maximum Power	370W
치수	Dimension	100 (W)×194 (D)×230 (H)
중량	Weight	4.2kg

⚠ 냉각에어가 정지한 상태로 스펀들에 절삭유나 냉각액이 절대로 들어가지 않게 해 주세요. 스펀들 내부에 절삭유나 냉각액이 투입되면, 내구성이 현저히 저하되거나 고장의 원인이 됩니다. ⚠ Please keep spindles away from cutting oil and coolant when the air supply is OFF. Penetration of cutting oil and coolant to the inner structure of spindle decreases durability and causes mechanical troubles.

**4대의 스펀들을 개별제어 할 수 있는 셀렉터**  
셀렉터 팩

Selector Pack

**MT01SP-100**

부속: AC100V코드

Standard Accessories : 100V AC Power Cord

**MT01SP-120 MT01SP-240**

부속: AC120V코드

부속: AC240V코드

Standard Accessories:  
120V AC Power Cord

Standard Accessories:  
240V AC Power Cord

● 본 제품은 스펀들 내부에 냉각액 등의 투입을 방지하기 위해 메인전원을 OFF로 해도 스펀들에 냉각에어를 계속 공급할 수 있는 구조로 되어 있습니다.  
에어 공급 정지는 공급원의 에어 밸브등으로 정지해 주세요.

● This Selector Pack, in an effort of protecting spindle from coolant and chips going inside, keeps blowing cooling air even when the main power supply switch is off.  
When you need to stop the air blow, please do so with the valve attached to the air supplier.

**사양 Specification**

전원	Power Source	AC100~240V
회전속도	Rotation Speed	1,000~60,000min <sup>-1</sup>
에어 소비량	Air Flow Volume	120ℓ/min(0.35~0.4Mpa)
치수	Dimension	100 (W)×194 (D)×230 (H)
중량	Weight	2.9kg



**셀렉터 팩(에어 밸브 부착)**  
Selector Pack with Air Valve

**MT01SP-100S**

부속: AC100V코드

Standard Accessories : 100V AC Power Cord

**MT01SP-120S MT01SP-240S**

부속: AC120V코드

부속: AC240V코드

Standard Accessories:  
120V AC Power Cord

Standard Accessories:  
240V AC Power Cord

● 메인전원의 ON/OFF로 연동 하고, 스펀들의 냉각에어 공급을 제어 하는 에어밸브등 셀렉터 팩 입니다.  
메인전원 ON : 에어 공급  
메인전원 OFF : 에어 정지

● Selector Pack with air valve that controls the supply of cooling air to spindle in conjunction with ON/OFF mode of main power supply.  
Main power is ON : Air supply is ON  
Main power is OFF : Air supply is OFF

**사양 Specification**

전원	Power Source	AC100~240V
회전속도	Rotation Speed	1,000~60,000min <sup>-1</sup>
에어 소비량	Air Flow Volume	120ℓ/min(0.35~0.4Mpa)
치수	Dimension	100 (W)×194 (D)×230 (H)
중량	Weight	3.0kg

※ 셀렉터 팩은 단독으로 사용을 할 수 없습니다. 반드시 콘트롤 팩과 같이 사용해 주세요.  
최대 4대의 스펀들모터를 접속 가능하나, 동시에 2대 이상을 사용할 수는 없습니다.  
※A maximum of 4 spindles can be connected. (2 cannot be used at the same time.)  
Selector Pack can not operate spindles by itself. It only works in conjunction with Control Packs.

※ 셀렉터 팩(에어 밸브 부착)을 사용하는 경우는 에어 밸브가 붙어 있지 않은 콘트롤 팩을 사용하지세요.  
※Use Control Packs without air valve for use in conjunction with Selector Packs with built-in air valve.

⚠ 냉각에어가 정지한 상태로 스펀들에 절삭유나 냉각액이 절대로 들어가지 않게 해 주세요. 스펀들 내부에 절삭유나 냉각액이 투입되면, 내구성이 현저히 저하되거나 고장의 원인이 됩니다. ⚠ Please keep spindles away from cutting oil and coolant when the air supply is OFF. Penetration of cutting oil and coolant to the inner structure of spindle decreases durability and causes mechanical troubles.

## 콘트롤 팩 표준부속품

### Standard Accessories to Control Pack

콘트롤 팩의 옵션 액세서리는 카타로그의 마지막 부분을 참조해 주세요.  
Please refer to the end of the catalogue for Optional Accessories of Control Pack.

#### AC코드 AC Power Cord



MT01CP-100  
◆CA20 (AC100V)



MT01CP-120  
◆CA21 (AC120V)



MT01CP-240  
◆CA22 (AC240V)

#### 에어 호스 Air Hose



◆AH6-40  
φ 6.0×4m

#### 브라켓트 Bracket



◆MTB1  
1Set : 2 Pieces



◆MTB2  
1Set : 2 Pieces

#### 고무 받침 Rubber Foot



◆MRZ2  
1Set : 4 Pieces

#### 조립 나사 Spanner Screw

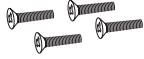

◆MRZ3  
1Set : 4 Pieces

## 외부 제어 기능 탑재

### EQUIPPED WITH EXTERNAL CONTROL OPERATION

#### ◆외부 입력

- 회전/정지 · 회전방향설정 · 회전속도설정
- 에어 해제 · 저회전속도설정

#### ◆외부 출력

- 회전중 · 회전방향 · 경고 · 에러 · 회전펄스
- 회전속도도달 · 실제회전속도 · 부하율 · 전류치

#### ◆기능/설정

- 최대회전속도제한 · 회전속도고정
- 회전방향제어방법 선택
- 회전속도제어방법 선택

#### ◆EXTERNAL INPUT

- Start/Stop · Setting Rotational Direction
- Setting Rotational Speed · Releasing errors

#### ◆EXTERNAL OUTPUT

- Rotating · Rotational Direction · Warning
- Error Notification · Rotational Pulse
- Rotational Speed Attainment
- Actual(Real X) Rotational Speed
- Load Factor · Current Value

#### ◆FUNCTION and SETTING

- Limitation for Maximum Speed of Rotation
- Rotational Speed Fixation
- Changeover of means for controlling Rotational Direction
- Changeover of means for controlling Rotational Speed

## 셋팅 자유

The Main Panel of Control/Selector Pack can be replaced for various angle installations.

콘트롤 팩의 셋팅으로, 메인 판넬을 가로방향으로 바꿀 수 있습니다. 또는, 콘트롤 팩 배면의 필터 판넬과 교환도 가능합니다.

The main panel can be placed horizontally, and also can be replaced at the rear depending on the installation space.



## 조합의 예 Combination Example

1. MS01-R03



4. MT01CP-\*\*\*



6. MAR1



2. MCC-40



3. MKD-40



5. MGC-30



1. 스트레이트 스피들 Straight Spindle	MS01-R03
2. 콜릿 척 스탠다드 φ 4.0 Collet Standard	MCC-40
3. 스피들 접속 코드 Spindle Connection Cord	MKD-40
4. 콘트롤 팩 Control Pack	MT01CP-***
5. 외부 콘트롤 케이블 External Control Cable	MGC-30
6. 에어 필터 유닛 Air Filter Unit	MAR1

## 셀렉터 팩 표준부속품 Standard Accessories to Selector Pack

#### AC코드 AC Power Cord



MT01CP-100  
◆CA20 (AC100V)



MT01CP-120  
◆CA21 (AC120V)



MT01CP-240  
◆CA22 (AC240V)

#### 셀렉터 통신 케이블 Selector Communication Cord



◆MTC-05  
50cm

#### 에어 마개 플러그 Air Stop Plug



◆MRZ1  
1Set : 4 Pieces

#### 셀렉터 접속 코드 Selector Connection Cord



◆MSC-05  
50cm

#### 브라켓트 Bracket



◆MTB1  
1Set : 2 Pieces



◆MTB2  
1Set : 2 Pieces

#### 고무 받침 Rubber Foot



◆MRZ2  
1Set : 4 Pieces

#### 조립 나사 Spanner Screw

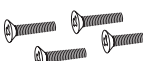

◆MRZ3  
1Set : 4 Pieces

### 표준 부속 Brackets attached as Standard Accessories

#### MTB1 배면 Backside

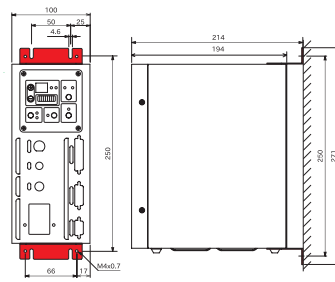

#### MTB2 바닥 Floor

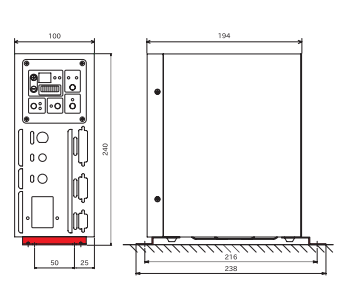

### ※옵션 Brackets sold as Optional Accessories

#### MTB3 수평형 Horizontal

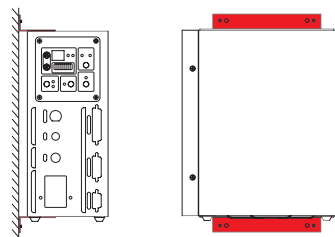

#### MTB4 연결 Coupling

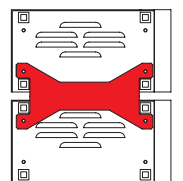

#### 천장 Pendant

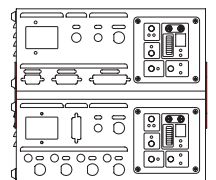
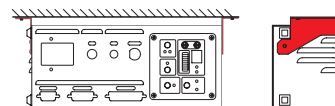

셀렉터 팩의 옵션 액세서리는 카타로그의 마지막 부분을 참조해 주세요.  
Please refer to the end of the catalogue for Optional Accessories of Selector Pack.

스트레이트 스피들/테이퍼샤크 스피들 옵션부품 *Optional Accessories Straight Spindle/ Taperd Shank Spindle*

콜렛 척 **Collets**



정밀형 **Ultra-Precision**

내경 Chuck Size	상품코드 Product Code
φ 1.0	MCC-10S
φ 1.5	MCC-15S
φ 2.0	MCC-20S
φ 2.5	MCC-25S
φ 3.0	MCC-30S
φ 3.175	MCC-3175S
φ 3.5	MCC-35S
φ 4.0	MCC-40S
φ 4.5	MCC-45S
φ 5.0	MCC-50S
φ 5.5	MCC-55S
φ 6.0	MCC-60S

보급형 **Standard**

내경 Chuck Size	상품코드 Product Code
φ 1.0	MCC-10
φ 1.5	MCC-15
φ 2.0	MCC-20
φ 2.5	MCC-25
φ 3.0	MCC-30
φ 3.175	MCC-3175
φ 3.5	MCC-35
φ 4.0	MCC-40
φ 4.5	MCC-45
φ 5.0	MCC-50
φ 5.5	MCC-55
φ 6.0	MCC-60

※φ0.2~φ0.9까지 φ0.1마다 구입 가능합니다. ※Chuck size φ 0.2~ φ 0.9 available upon request.

스피들 접속코드  
**Spindle Connection Cord**



- ◆MKD-30 (3m)
- ◆MKD-40 (4m)
- ◆MKD-60 (6m)
- ◆MKD-80 (8m)

스트레이트 스피들/테이퍼샤크 스피들 표준 부속품

*Standard Accessories for Straight Spindle/ Tapered Shank Spindle*

척 너트 **Chuck Nut**



◆MCN1

스패너 **Spanner**



◆MSP1  
1Set : 2 Pieces

에어 호스 **Air Hose**



◆AH4-40  
φ 4.0×4m

※옵션 **Optional**

- ◆AH4-30 φ 4.0×3m
- ◆AH4-60 φ 4.0×6m
- ◆AH4-80 φ 4.0×8m

콘트롤 팩/셀렉터 팩 옵션 부품 *Optional Accessories Control Pack/ Selector Pack*

에어 필터 유닛  
**Air Filter Unit**



◆MAR1

- 필터
- 레귤레이터
- 밸브

※여과도  
먼지 제거 5μm  
타르 제거 0.3μm

중량 0.6kg

외부 콘트롤 케이블  
**External Control Cable**



◆MGC-30  
3m

브라켓트 **Bracket**



◆MTB3  
1Set : 2 Pieces



◆MTB4  
1Set : 2 Pieces

셀렉터 팩 표준 부속품 *Standard Accessories for Selector Pack*

셀렉터 접속 코드  
**Selector Connection Cord**



◆MSC-05  
50cm

셀렉터 통신 케이블  
**Selector Communication Cable**



◆MTC-05  
50cm

에어 마개 **Air Stop Plug**

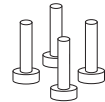

◆MRZ1  
1Set : 4 Pieces

콘트롤 팩/셀렉터 팩 표준 부속품 *Standard Accessories for Control Pack/ Selector Pack*

AC코드 **AC Power Cord**



MT01CP-100  
◆CA20 (AC100V)



MT01CP-120  
◆CA21 (AC120V)



MT01CP-240  
◆CA22 (AC240V)

브라켓트 **Bracket**



◆MTB1  
1Set : 2 Pieces



◆MTB2  
1Set : 2 Pieces

에어 호스 **Air Hose**



콘트롤 팩 전용 부속  
Only Control Pack attached.

◆AH6-40  
φ 6.0×4m

※옵션 **Optional**

- ◆AH6-30 φ 6.0×3m
- ◆AH6-60 φ 6.0×6m
- ◆AH6-80 φ 6.0×8m

고무 받침 **Rubber Foot**



◆MRZ2  
1Set : 4Pieces

조립 나사 **Spanner Screw**



◆MRZ3  
1Set : 4 Pieces